

**TEST B OPERABILITY**

TEST FLUID: WATER

TEST FROM THE INLET SIDE

TEST PRESSURE: 500 kPa

TEST DURATION: 5 MIN

**TEST C OPERABILITY**

TEST FLUID: WATER

TEST FROM THE OUTLET SIDE

TEST PRESSURE: 27 kPa

TEST DURATION: 5 MIN

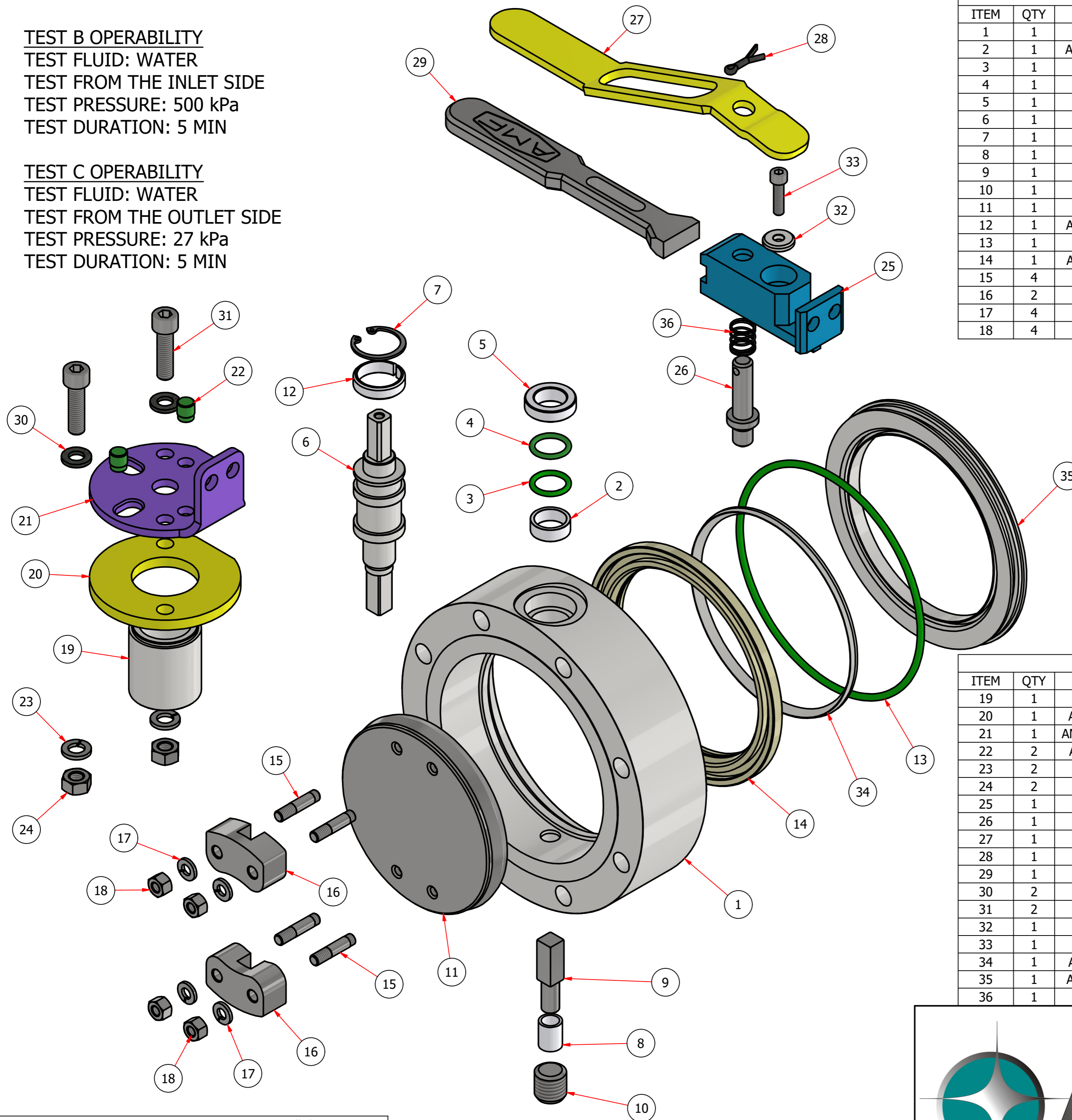

PARTS LIST					
ITEM	QTY	PART NUMBER	MATERIAL	DESCRIPTION	MASS
1	1	AMF_BF_CH_100_MAN_ADR_316_MAIN BODY	316L	RB 170 X 43	3,726 kg
2	1	AMF_BF_CH_100_MAN_ADR_316_TOP SHAFT SPACER	316L	RB 25 X 10	0,006 kg
3	1	BS114 VE O-RING	VE	15.54 ID x 2.62 CS, Viton EPS	0,002 kg
4	1	BS114 VITON O-RING	VITON	15.54 ID x 2.62 CS, VITON	0,002 kg
5	1	AMF_BF_CH_ADR_316_TOP SHAFT BUSH	PTFE	RB 30 X 12	0,018 kg
6	1	AMF_BF_CH_100_MAN_ADR_316_TOP SHAFT	316L	RB 30 X 120	0,205 kg
7	1	Circlip 26mm x 1,2	A2	Internal Circlip 26mm	0,002 kg
8	1	AMF_BF_CH_ADR_316_BOTTOM SHAFT BUSH	316L	RB 20 X 19	0,005 kg
9	1	AMF_BF_MAN_ADR_BOTTOM SHAFT	316L	RB 16 X 45	0,027 kg
10	1	M16 x 16 Grub Screw	A2	16mm OD x 16mm Long	0,020 kg
11	1	AMF_BF_CH_100_MAN_ADR_316_SEALING DISC	316L	PL 16 X 109 x 109	0,948 kg
12	1	AMF_BF_CH_100_ADR_316_TOP_SHAFT GUIDE BUSH	PTFE	RB 28 X 10	0,001 kg
13	1	3.53 x 123.00 Viton O-Ring	VITON	123.00 ID x 3.53 CS, Viton	0,031 kg
14	1	AMF_BF_CH_100_MAN_ADR_316_TEFLON SEAL RING	TEFLON	RB 131 X 12	0,021 kg
15	4	AMF_BF_80/100_ADR_316L_STUDS	316L	M6 x 27mm long	0,006 kg
16	2	BF_MAN_ADR_SHAFT PLATE	316L	RB 45 x 19	0,085 kg
17	4	M6 Spring Washer	A2	6mm ID Washer	0,001 kg
18	4	M6 Nut	A2	Full Nut	0,003 kg

**NOTE:**  
ALL THREADED PARTS TO BE GREASED  
WITH COPPER COMPOUND

PARTS LIST					
ITEM	QTY	PART NUMBER	MATERIAL	DESCRIPTION	MASS
19	1	AMF_BF_CH_100_MAN_ADR_316_GLAND BOX	316L	RB 40 X 42	0,153 kg
20	1	AMF_BF_CH_100_MAN_ADR_316_GLAND BOX PLATE	316L	PL 6 x 78 x78	0,164 kg
21	1	AMF_BF_CH_100_MAN_ADR_316_HANDLE LOCK PLATE	316L	PL 4.5 x 80 x 110	0,174 kg
22	2	AMF_BF_CH_100_MAN_ADR_316_HANDLE LOCK PIN	316L	RB 10 X 13	0,005 kg
23	2	M8 Spring Washer	A2	8mm ID Washer	0,002 kg
24	2	M8 Nut	A2	Full Nut	0,006 kg
25	1	AMF_BF_CH_100_MAN_ADR_316_HANDLE BLOCK	316L	RB 45 x 98	0,251 kg
26	1	AMF_BF_CH_100_MAN_ADR_316_HANDLE PIN	316L	RB 20 X 53	0,035 kg
27	1	AMF_BF_CH_100_MAN_ADR_316_HANDLE LATCH	316L	PL 4.5 x 220 x35	0,153 kg
28	1	Split Pin 3,0 x 35 Long	A2	Split Pin	0,001 kg
29	1	AMF_BF_CH_100_MAN_ADR_316_HANDLE PLATE	316L	PL 10 x 27 x 162	0,238 kg
30	2	M8 Washer	A2	8mm ID Washer	0,002 kg
31	2	M8 x 30 Allen Cap Screw	A2	8mm OD x 30mm Long A.C.S.	0,019 kg
32	1	AMF_BF_MAN_ADR_316_HANDLE CENTER WASHER	316L	RB 16 X 6	0,004 kg
33	1	M5 x 20 Allen Cap Screw	A2	5mm OD x 20mm Long A.C.S.	0,005 kg
34	1	AMF_BF_CH_100_MAN_ADR_316_PTFE SEAL INSERT	316L	4" SCH 40 PIPE - 8mm Long	0,012 kg
35	1	AMF_BF_CH_100_MAN_ADR_316_SEAL COVER PLATE	316L	RB 135 X 12	0,336 kg
36	1	Spring AMF-026	SS	23FL x 12.7OD , 18SWG , 6TC	0,001 kg

NO TRANSFER OF INTELLECTUAL PROPERTY : Any & all drawings, documentation, information or data provided by AMF to be used solely for the use intended by AMF, nor may it be shared, copied, distributed or disseminated in any manner whatsoever. All intellectual property, including AMF's drawings, shall remain the sole property of AMF.

AMF

ALLGEMEINE MASCHINEN FABRIK

APPROVED R.P.M.J.		
TITLE <b>BUTTERFLY VALVE 100mm MANUAL PARTS ASSEMBLY</b>		
SIZE	DWG NO	REV
A2	AMF_BF_CH_100_MAN_ADR_316L	2
SCALE	SHEET 1 OF 1	
1 : 1		