

TEST B OPERABILITY
 TEST FLUID: WATER
 TEST FROM THE INLET SIDE
 TEST PRESSURE: 600 kPa
 TEST DURATION: 5 MIN

TEST C OPERABILITY
 TEST FLUID: WATER
 TEST FROM THE OUTLET SIDE
 TEST PRESSURE: 27 kPa
 TEST DURATION: 5 MIN

NO TRANSFER OF INTELLECTUAL PROPERTY : Any & all drawings, documentation, information or data provided by AMF to be used solely for the use intended by AMF, nor may it be shared, copied, distributed or disseminated in any manner whatsoever. All intellectual property, including AMF's drawings, shall remain the sole property of AMF.

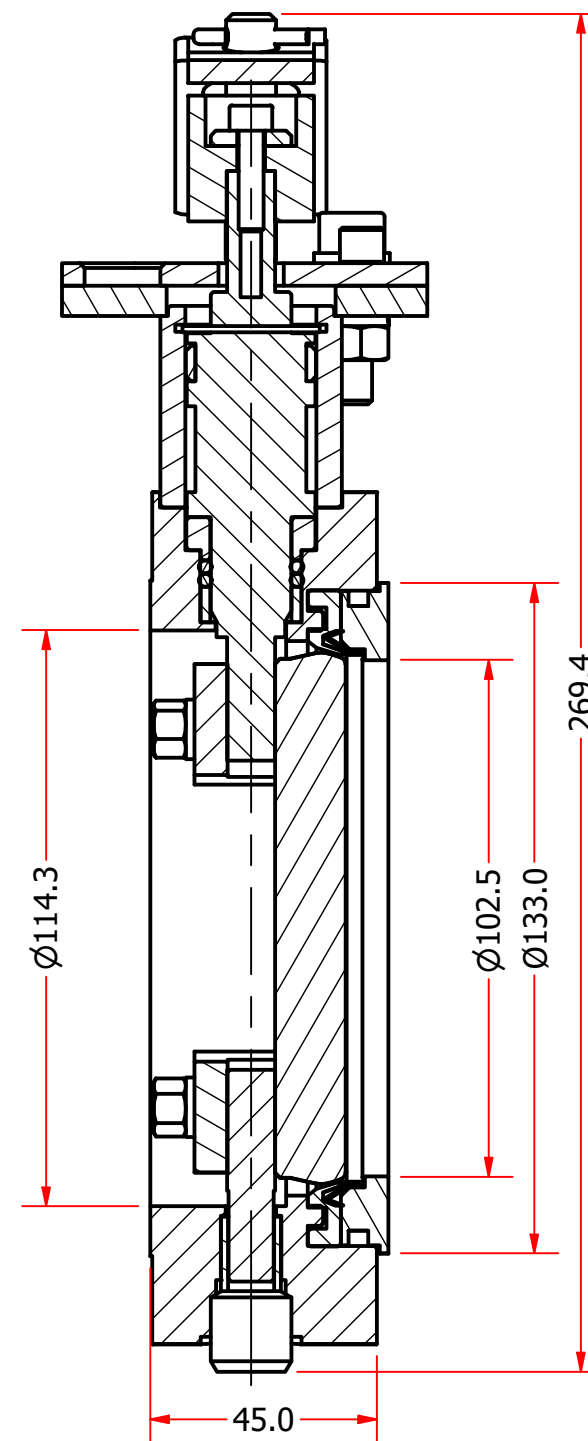

SECTION A-A
 SCALE 1 / 1.5

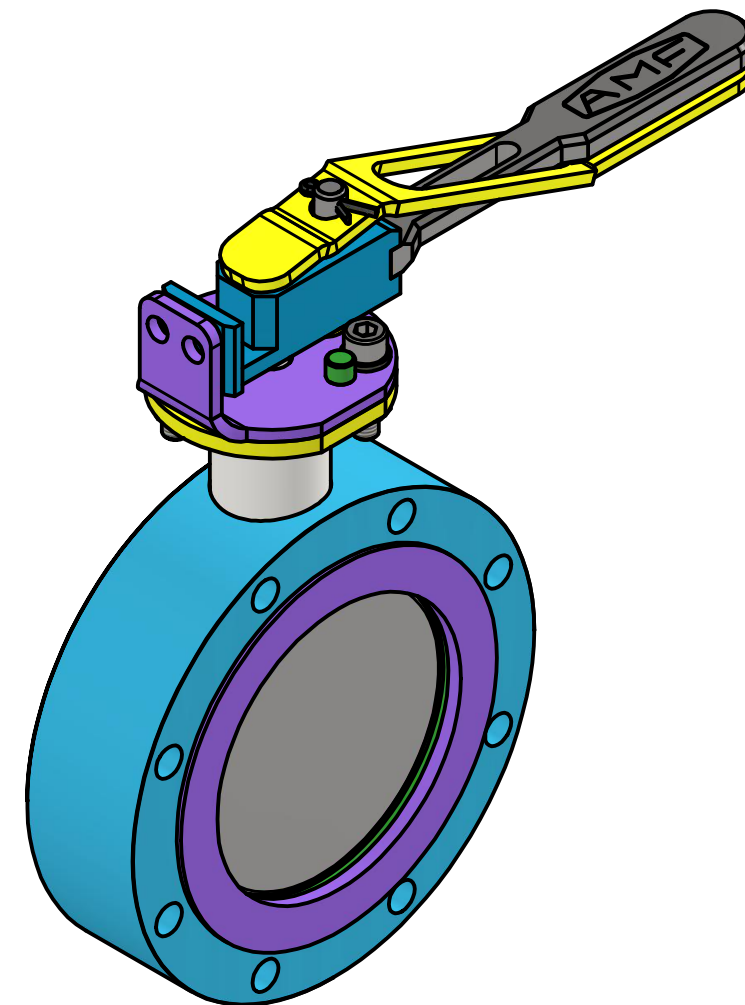

APPROVED
 R.P.M.J.

TITLE

CHEMICAL BUTTERFLY VALVE 100mm MANUAL
 GENERAL ARRANGEMENT

SIZE	DWG NO	REV
A3	AMF_BF_CH_100_MAN_ADR_316L	2

SCALE	1 : 1	SHEET 1 OF 1
-------	-------	--------------