

PARTS LIST					
ITEM	QTY	PART NUMBER	MATERIAL	DESCRIPTION	MASS
1	1	AMF_RV_32VP_SG_ADR_316_M51PLUG	316L	RB 65 X 15	0,23 kg
2	1	AMF_RV_32VP_ADR_316_SPRING	S/S	AMF-007	0,015 kg
3	1	AMF_RV_32VP_ADR_316_FEMALE PLUNGER	316L	RB 40 X 24	0,101 kg
4	1	AMF_RV_32VP_ADR_316_22MM BALL 316	316L	22 x 22	0,006 kg
5	1	AMF_RV_32VP_ADR_316_MALE PLUNGER	316L	RB 50 X 25	0,114 kg
6	1	AMF_RV_32VP_ADR_316_MAIN BODY	316L	RB 65 X 58	0,282 kg
7	1	AMF_RV_32VP_ADR_316_STRAINER	316	STRAINER	0,014 kg
8	1	AMF_RV_32VP_SG_ADR_316_M51MAIN BODY	316L	RB 65 X 32	0,19 kg
9	1	AMF_RV_32VP_SG_ADR_316_STRAINER SMALL	316	STRAINER SMALL	0,007 kg

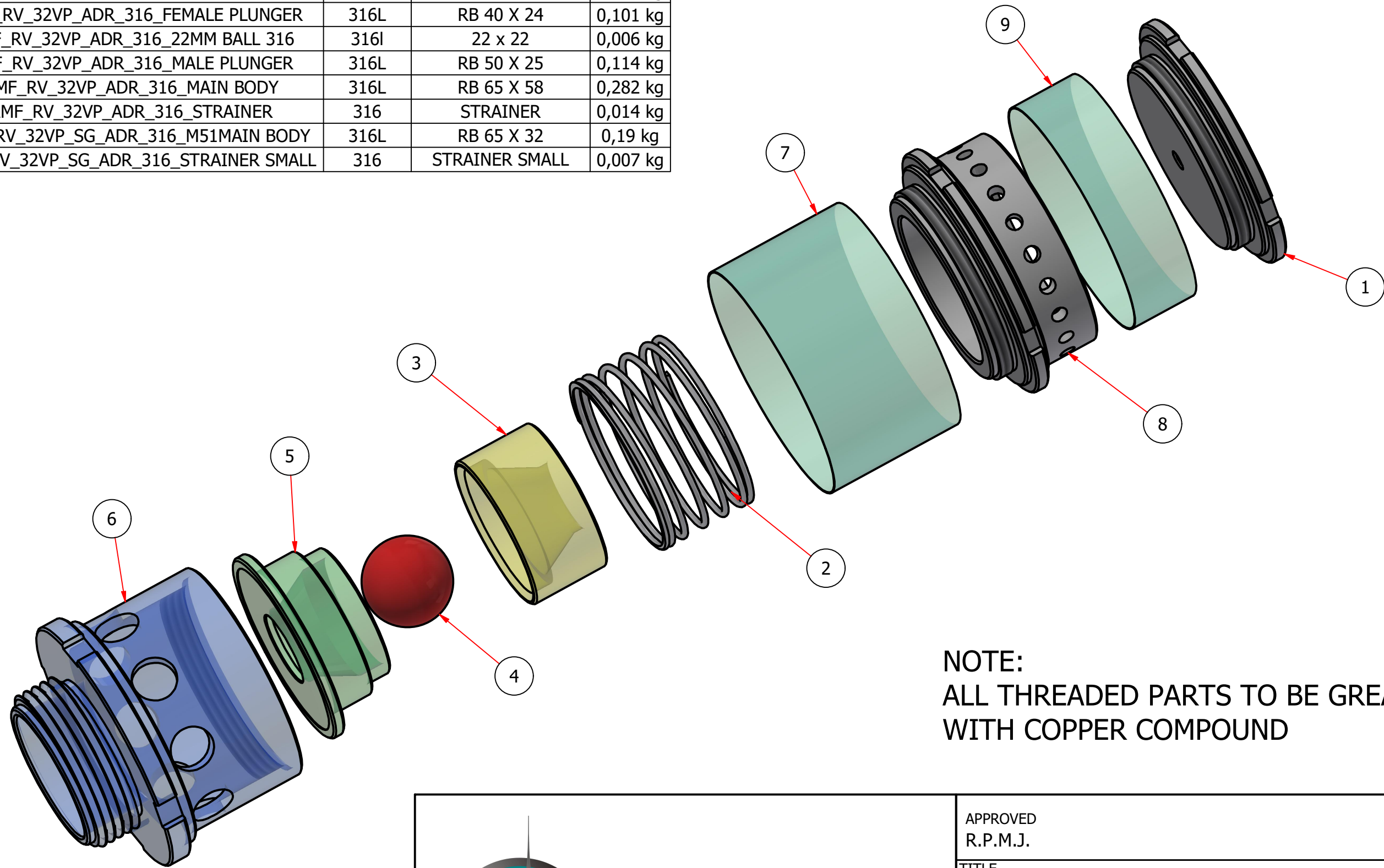

NOTE:
ALL THREADED PARTS TO BE GREASED
WITH COPPER COMPOUND



APPROVED R.P.M.J.		
TITLE 32MM COMBINED VACUUM PRESSURE VENT PARTS ASSEMBLY		
SIZE A3	DWG NO AMF_RV_32VP_SG_ADR_316L	REV 5
SCALE 1 : 1	SHEET 1 OF 1	

NO TRANSFER OF INTELLECTUAL PROPERTY : Any & all drawings, documentation, information or data provided by AMF to be used solely for the use intended by AMF, nor may it be shared, copied, distributed or disseminated in any manner whatsoever. All intellectual property, including AMF's drawings, shall remain the sole property of AMF.